

Andalusia
edition

Poptropica® English

COMPACT
ACTIVITY BOOK

4

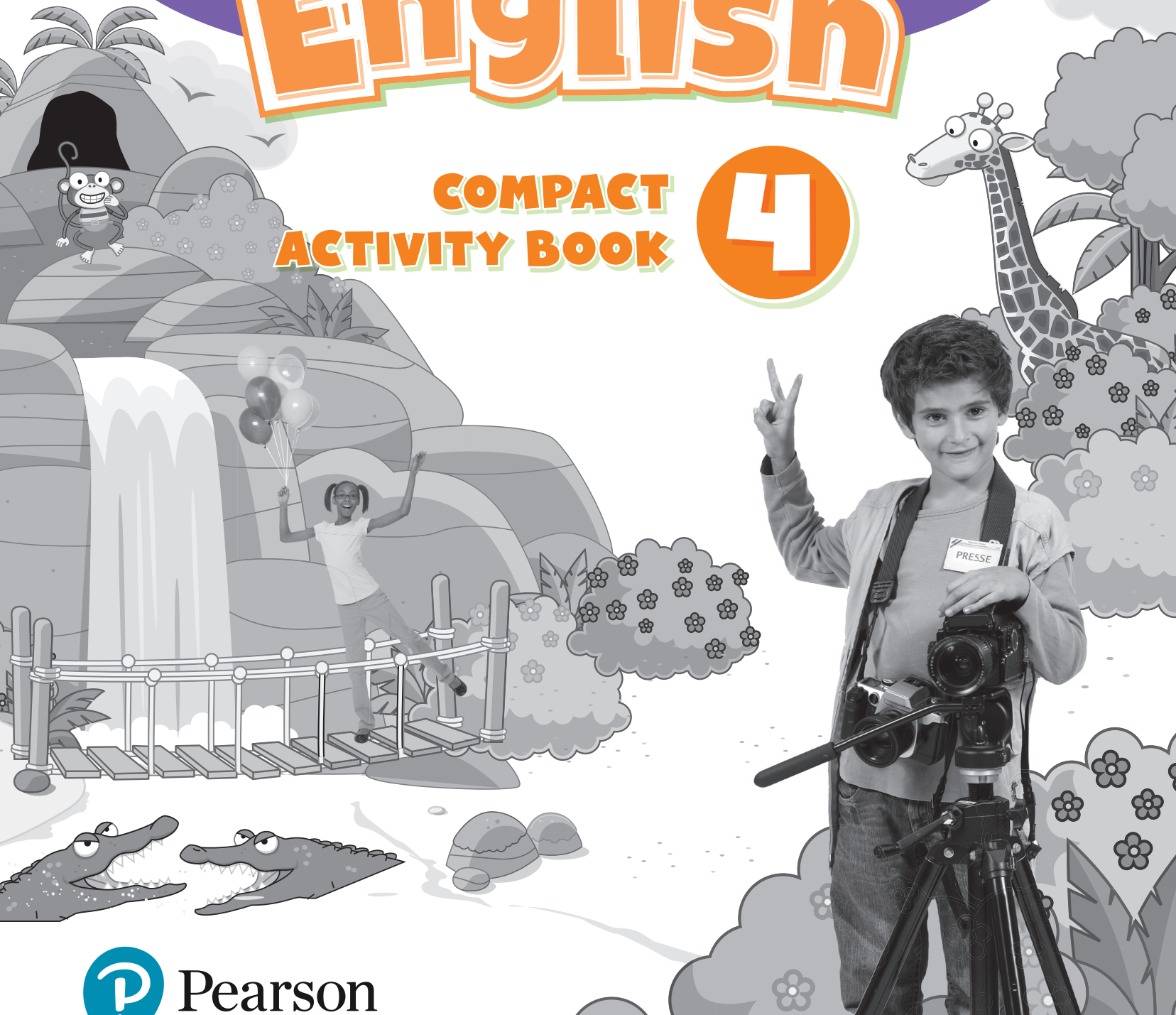

 Pearson

Sagrario Salaberri • Viv Lambert
Series advisor: David Nunan

Poptropica® English

Andalusia
edition

COMPACT ACTIVITY BOOK **4**

Contents

Welcome

- 1 Free time
- 2 Animals
- 3 Weather
- 4 My week
- 5 Jobs
- 6 Rainforest
- 7 Feelings
- 8 By the sea

Goodbye

Festivals

Picture dictionary



Welcome

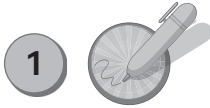

1

Read and write *Sophie, Oliver, Uncle James* or *Finley Keen*. Then match.

1 He's ten.

He's got blond hair.

He likes films.

His name is Oliver .

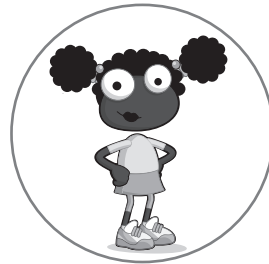

2 She's nine.

She's got black hair.

She loves Finley Keen.

Her name is _____.



3 He's got black hair.

He's a film star.

His name is _____.

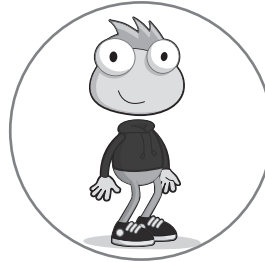

4 He's got blond hair.

He's wearing a red sweater.

His name is _____.

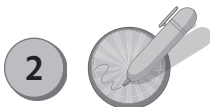
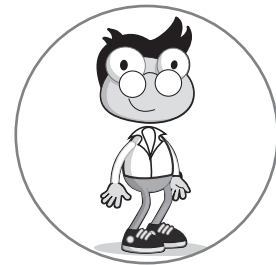

2

Read and complete. Then draw yourself.

I'm _____. I've _____ hair.

I like _____.

My _____.

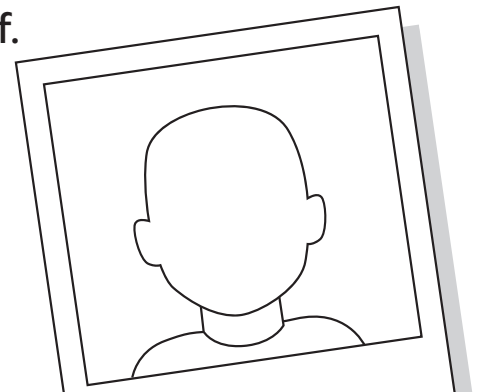

3  Look and write. Use the words in the box.

get up go home go to bed go to school
have breakfast have dinner

Morning	Afternoon	Evening	Night
have breakfast			

4  Look and number. Then listen and check.

March **September** June **December**

May **November** February April

January 1 August **October** July

5  Listen and circle.

13 (30) 14 40 15 50 16 60 17 70
18 80 19 90

6  Say a number from Activity 5. Ask your friend to point.

1

Free time

1  Read and match.

playing computer games

1 

2 

watching TV

playing the guitar

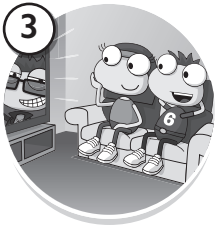
3 

4 

5 

skiing

cooking

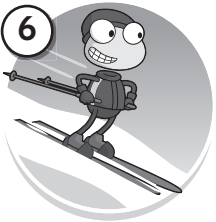
6 

7 

chatting online

skateboarding

2  Look and write.

1 He likes watching TV.

2 He _____.



3 He doesn't like _____.

4 He doesn't _____.

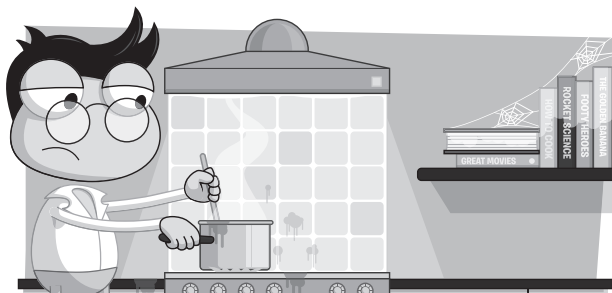

3  Read and tick (✓) or cross (X).

Sophie doesn't like skiing.
She likes cooking and she likes playing computer games. She likes reading.

Oliver likes cooking and he likes skateboarding. He doesn't like reading. He likes skiing.

Sophie

Oliver

4  Look at Activity 3 and write. Use the words in the box.

No, he doesn't. No, she doesn't. Yes, he does. Yes, she does.

- 1 Does Sophie like cooking? Yes, she does.
- 2 Does Oliver like skateboarding? _____
- 3 Does Sophie like skiing? _____
- 4 Does Oliver like cooking? _____
- 5 Does Sophie like playing computer games? _____
- 6 Does Oliver like reading? _____

5  Read and circle.





1  I like don't like
skateboarding.

2  I like don't like
riding my scooter.

3  I like don't like
playing computer games.

4  I like don't like
playing the guitar.

6  Read and tick (✓) or cross (X). Then ask your friend.

Do you like...?	Me	My friend
 riding your bike		
 skateboarding		
 playing computer games		
 riding your scooter		
 playing the guitar		

7  Look at Activity 6 and complete the sentences.

I like _____ . My friend likes _____ .

I don't like _____ . He/She doesn't like _____ .

13



What do you like? Tick (✓) or cross (X).
Then write.

WRITING





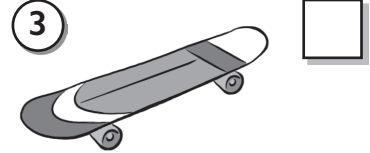



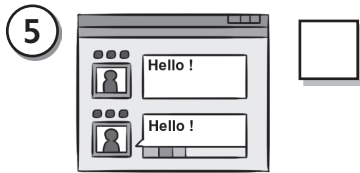

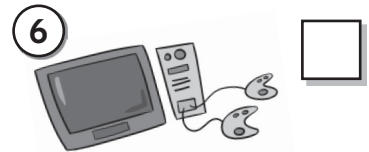

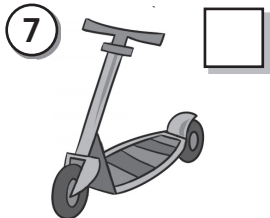

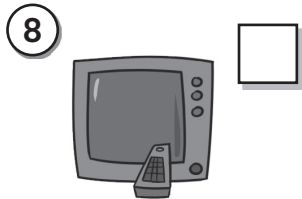

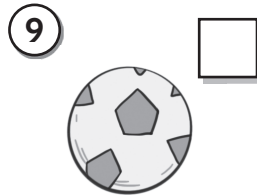

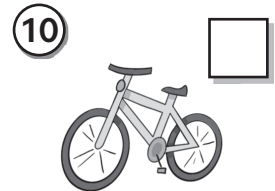

14



Ask a friend. Write two sentences.



My friend likes swimming
and watching TV. She
doesn't like cooking.

My friend _____ and _____.

He/She _____.

18



Complete the puzzle.



1 r

2 s e d i g

3 l a y

4 d

5 i m m

6 e n n g

7 k n g

19



Read, think and complete.



cooking ✓ reading ✓
 playing football ✓
 riding my bike ✓
 watching TV ✗



playing computer games ✓
 chatting online ✓
 playing the guitar ✓
 skateboarding ✗ skiing ✗

He likes ¹ cooking and ² _____. He likes ³ _____ football and ⁴ _____ his ⁵ _____. He doesn't like ⁶ _____.

She ⁷ likes playing computer games and chatting online.

She ⁸ _____ playing the guitar. She ⁹ _____ skiing or skateboarding.

I CAN

- I can identify some free-time activities.
- I can talk about what people like doing in their free time.
- I can understand texts about what others like doing.
- I can write about what I and other people like doing.





2

Animals

1  Listen and number.

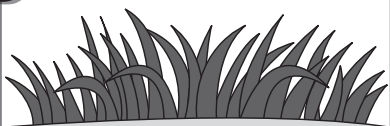
a 

b 

c 

d 

e 

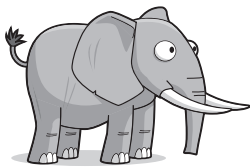
f 

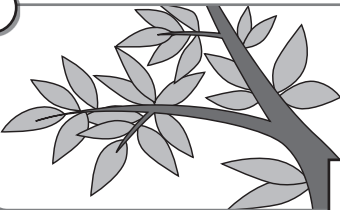
g 

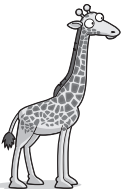
h  1

2  Look and write. Use the words in the box.

crocodile elephant giraffe hippo lion monkey

1  It's a lion.

2 

3 

4 

5 

6 

5  Read and circle.

- 1 Lions **live** lives in Africa. 2 Oscar **live** lives with me.
 3 Lions **run** runs very fast. 4 Lions **eat** eats meat.
 5 Oscar **run** runs very fast. 6 Oscar **eat** eats meat.

6  Listen and number.

a 

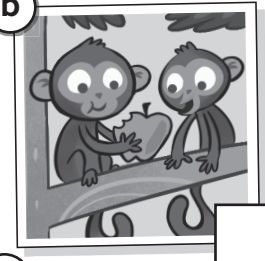
b 

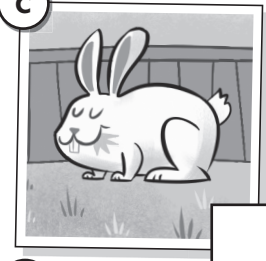

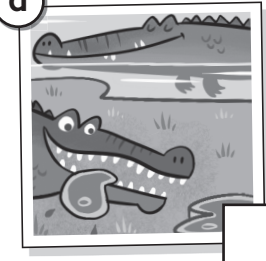

c 

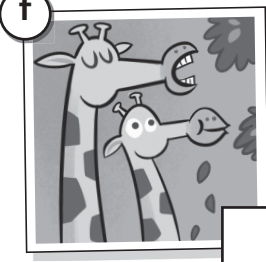
d 

e  1

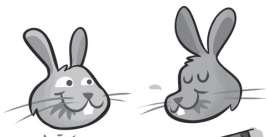
f 

7  Look, think and complete.

- 1 Rabbits  eat grass.
- 2 My dog  _____ meat.
- 3 Monkeys  _____ fruit.
- 4 My cat  _____ meat.
- 5 Giraffes  _____ leaves.

14



Draw your favourite animal. Write notes.



15



Write about your favourite animal. Then describe it to your friend.



My favourite animal lives in Africa. It eats leaves and fruit. It can run. It likes eating leaves from tall trees.

My favourite animal lives in _____.

It eats _____.

It _____.

18



Find and write the words.



1 onil
lion

2 ynekom

3 licordeco

4 popih

19



Write about monkeys. Use the words in the box.

1 Monkeys eat fruit.

2 _____

3 _____

4 _____

5 _____

climb forests
fruit long tails ski

Tell me about monkeys!



20



Now ask and answer questions with your friend.

What do monkeys eat?

They eat fruit.

I CAN

- I can identify some animals and their food.
- I can talk about animals.
- I can understand short texts about animals.
- I can write about animals.



3

Weather

1  Read and match. Then say.

humid

lightning

stormy

thunder

warm

wet

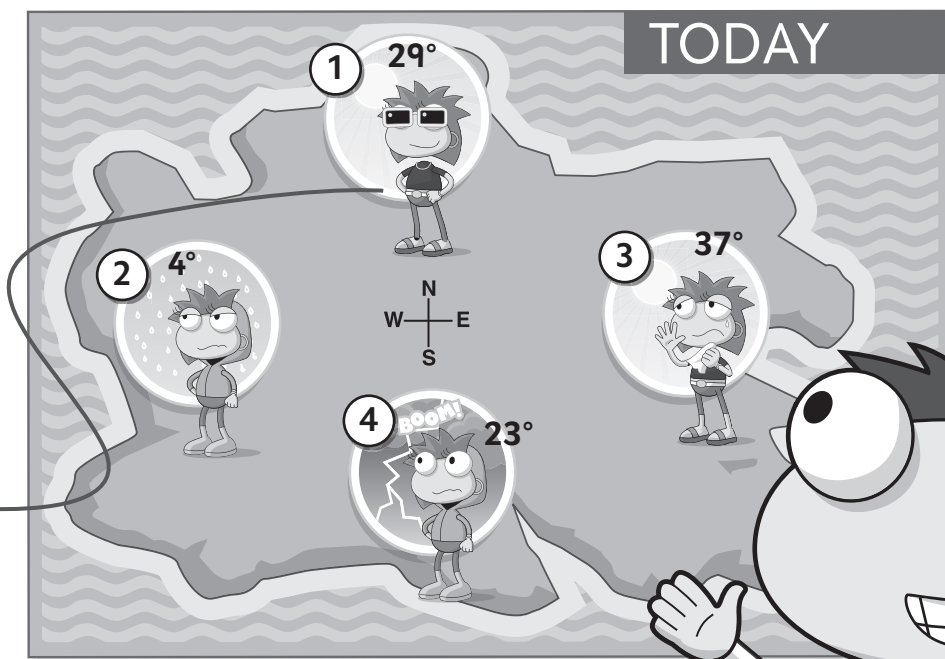

2  Look at Activity 1 and write. Use the words in the box.

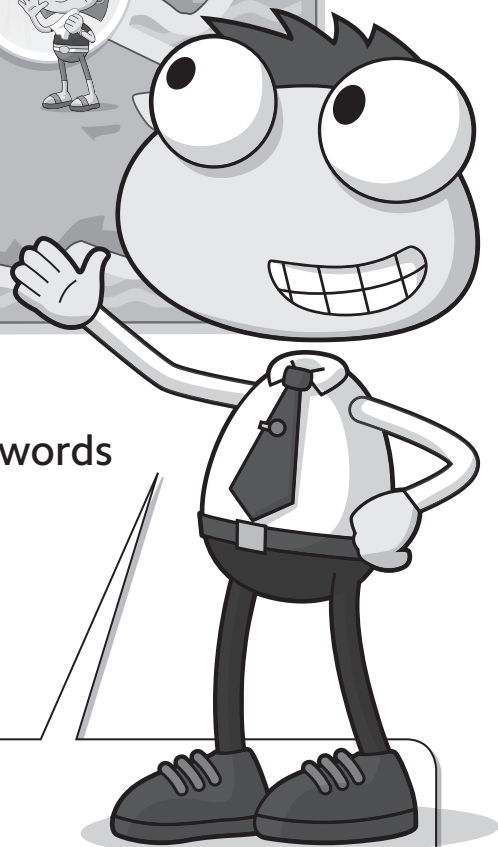

cold degrees hot humid
lightning temperature thunder

- 1 Here, the temperature is warm.
- 2 Here, it's 4 _____. It's wet and _____.
- 3 Here, it's _____ and _____.
- 4 Here, there is _____ and _____.

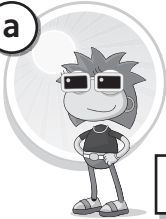
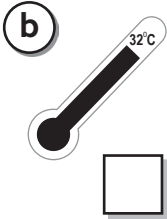
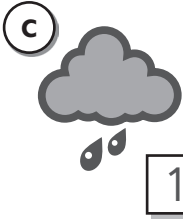

3  Listen and number. Then say.

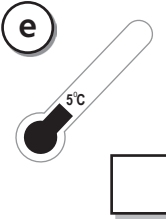
a  b  c  1

d  e  f 

4  Look and write. Use the words in the box.

cold hot humid lightning thunder warm wet

1 What's the weather like today?

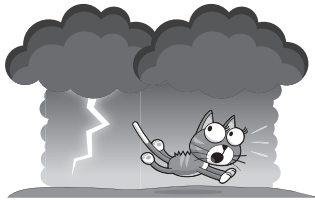

There's _____ thunder _____ and
_____ lightning _____.

2 What's the weather like today?

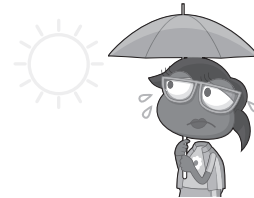

It's _____.

3 What's the weather like today?

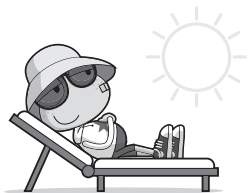

It's _____.

4 What's the weather like today?



It's _____.

5 What's the temperature today?

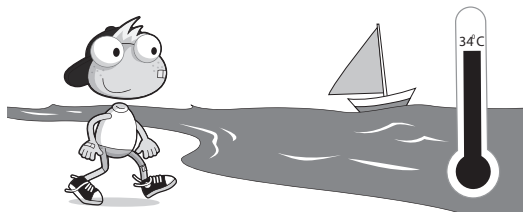

It's _____.

6 What's the temperature today?



It's _____.

SONG

5  Look and write. Use the words in the box.

autumn spring summer winter



It's autumn.

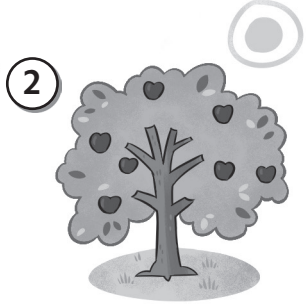

It's _____.



It's _____.



It's _____.

6  Look and write. Then match.

autumn fly rains snows summer swim

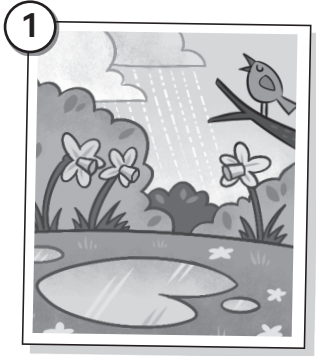

It rains
in the spring.

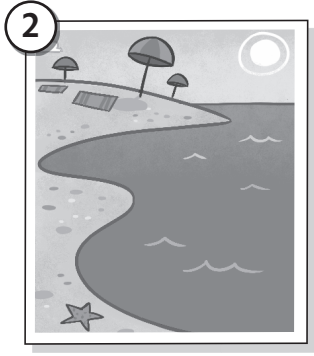

The sun shines
in the _____.



The wind blows
in the _____.



It _____
in the winter.

I play in
the snow.



I splash
in the rain.



1

I _____
my kite.

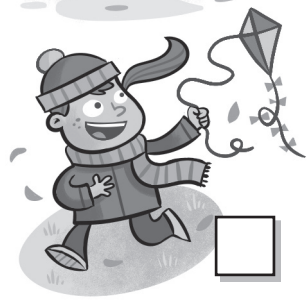

I _____
in the sea.





12 Draw and write notes about your favourite season.

My favourite season

weather

I like...

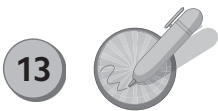

13 Write about your favourite season. Then tell your friend.



My favourite season is winter.
It's cold and snowy. I like
playing in the snow.

My favourite _____.

It's _____.

I like _____.

16



Complete the puzzle.



Across →

1 It's rainy. It's .

3 It's hot and .

5 The ____ today is 18°.

7 18° means 18 ____.

Down ↓

2 I can hear .

4 I can see .

6 It's . Let's go to the beach.

8 It's . We can't go to the beach.

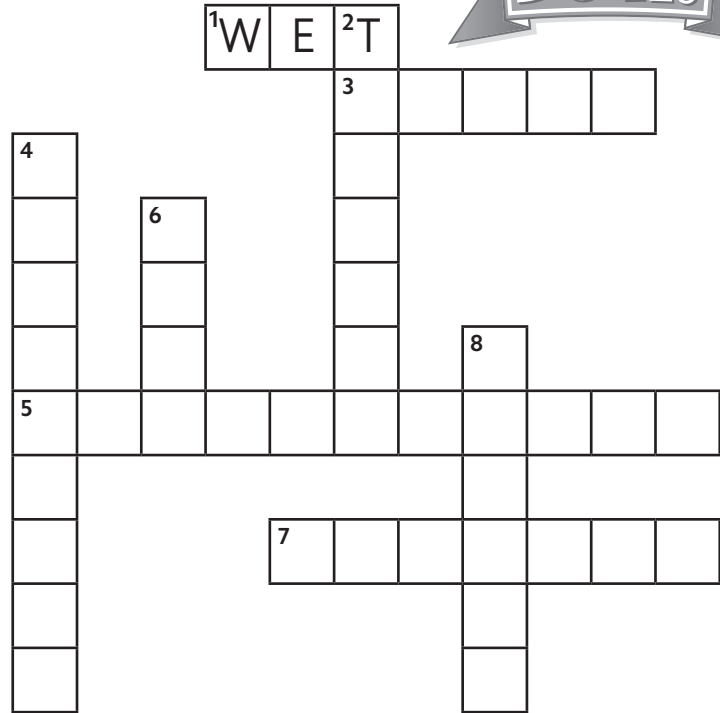

17



Read the email. Then complete the answer.

Hi! How are you? It's winter here and it's really cold. I love winter. It's my favourite season. I like skiing and playing in the snow with my friends. What's your favourite season? I don't like spring, sometimes there are tornadoes. I don't like rain but my little sister loves it, she jumps and splashes. She's only five.
Bye! :-)
Joe

Hi Joe,
It's ¹ summer here and it's ² _____.
I ³ _____ summer because I'm on holiday.
In the summer I ⁴ _____ to the park and play ⁵ _____ with my friends. It's my ⁶ _____ season. I ⁷ _____ like autumn because it's cold and windy. I've got a sister, too. She's thirteen. Bye,
Claire

I CAN

- I can identify some weather words.
- I can talk about the seasons and activities.
- I can understand a text about hurricanes.
- I can write about the weather and seasons.



4

My week

1  Look and write. Use the words in the box.

do gymnastics do karate have ballet lessons learn to cook
have Music lessons ~~learn to draw~~ practise the piano
study English study Maths

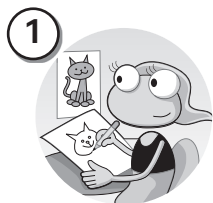

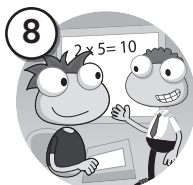
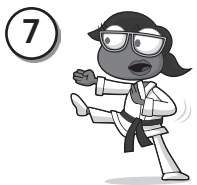
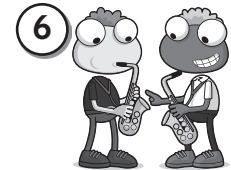
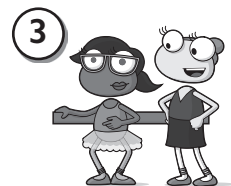
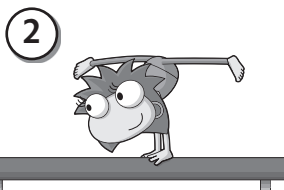

learn to draw

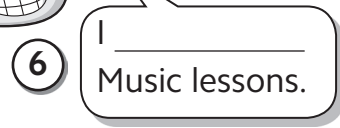
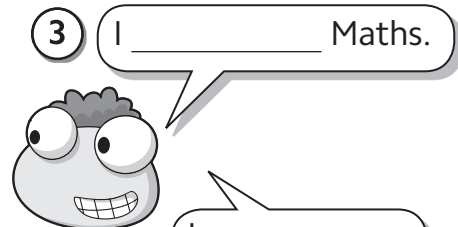
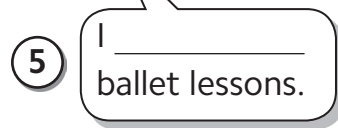
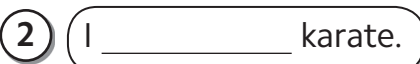
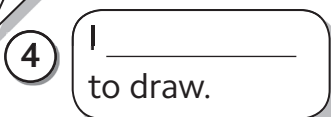
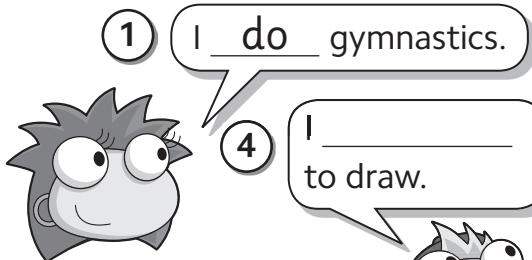

2  Look, think and complete. do have learn study

What do you do on Saturdays?



3  Listen and draw the times.

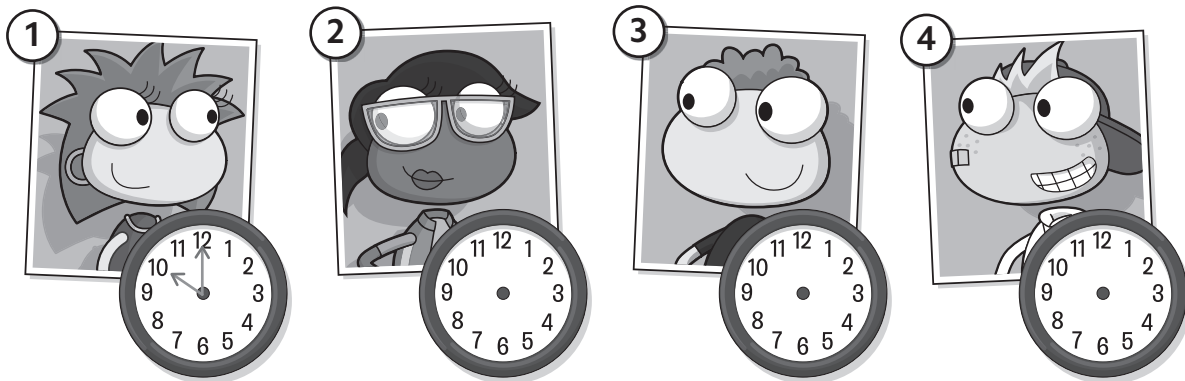

4  Look at Activity 3 and complete the sentences.

4 o'clock ~~10 o'clock~~ half past 2 11 o'clock

- 1 She does gymnastics at 10 o'clock.
- 2 She has ballet lessons at _____.
- 3 He goes swimming at _____.
- 4 He goes skateboarding at _____.

5  Look at the diary and write.

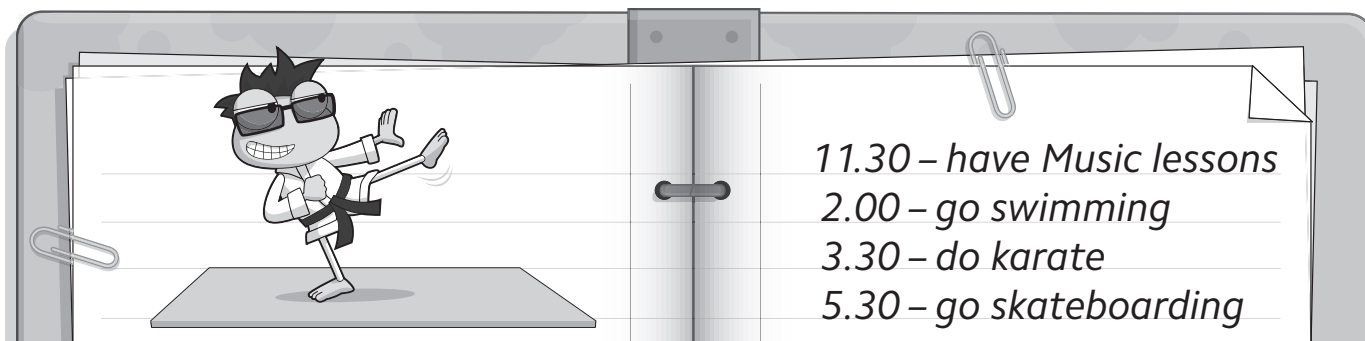

- 1 He has Music lessons at half past 11.
- 2 _____
- 3 _____
- 4 _____

6



How does he/she go to the park?
Look, think and write.

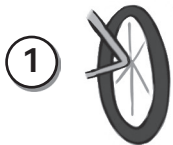

He goes by bike.



She goes by _____.



She goes by _____.



He _____.

7



Follow and write.

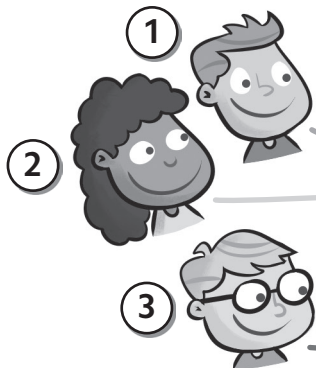

1 He goes to school by bike.

2 She _____.

3 He _____.



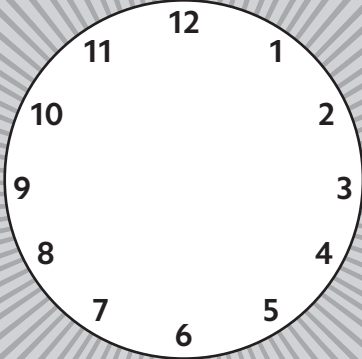

15  What do you do on Saturdays? Draw the times and write notes.

morning

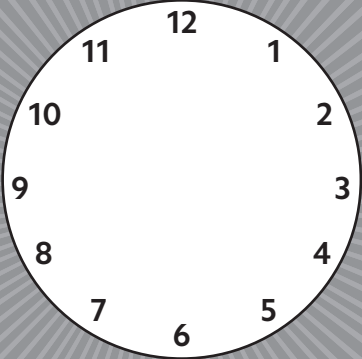

afternoon



16  Write about what you do on Saturdays. Then tell your friend.



On Saturdays, in the morning, I study English. At half past 11 I go swimming. In the afternoon I play football at 5 o'clock.

On Saturdays, in the morning, _____

_____.

In the afternoon, _____

_____.

19



Write the letters and find the answer.



1 I have balle t lessons.



2 I have M u sic lessons.



3 I go skat e boarding.



4 I go s wimming.



5 I d o kar o te.



6 I do g y mnastics.

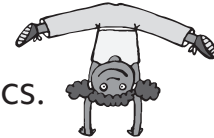

What day is it? T _ _ _ _ _

20



Look at the diary and write about your day.

Monday

9 school (boat)

1 I go to school by boat at 9 o'clock.

11 karate (the park)

2 _____

2 swimming (a river)

3 _____

4 party

4 _____

8 home (plane)

5 _____

I CAN

- I can identify some scheduled activities.
- I can talk about scheduled activities.
- I can understand texts about how others go to school.
- I can write about scheduled activities and my weekend.











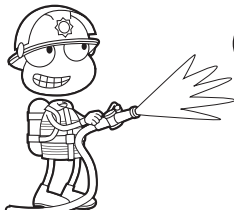

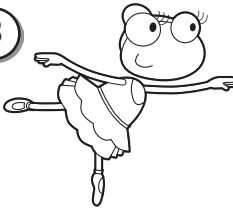
5

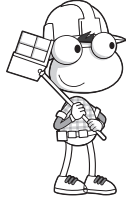
Jobs

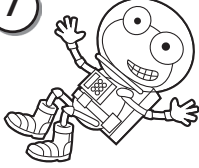
1  Complete the words. Use the letters in the box.

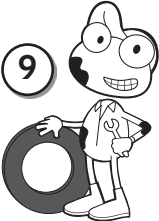
a e i
o u

<p>1 </p> <p>fire<u>f</u>ire<u>f</u>ight<u>e</u>r</p>	<p>2 </p> <p>b<u>o</u>sk<u>e</u>tb<u>a</u>ll pl<u>a</u>y<u>e</u>r</p>	<p>3 </p> <p>b<u>a</u>ll<u>e</u>t d<u>a</u>nc<u>e</u>r</p>	<p>4 </p> <p>p<u>o</u>l<u>i</u>c<u>e</u> _ffic<u>e</u>r</p>	<p>5 </p> <p>b<u>u</u>ild<u>e</u>r</p>
<p>6 </p> <p>f<u>o</u>lm st<u>a</u>r</p>	<p>7 </p> <p>_str<u>o</u>n<u>a</u>ut</p>	<p>8 </p> <p>ph<u>o</u>t<u>o</u>gr<u>a</u>ph<u>e</u>r</p>	<p>9 </p> <p>m<u>e</u>ch<u>a</u>n<u>i</u>c</p>	

2  Look and write.

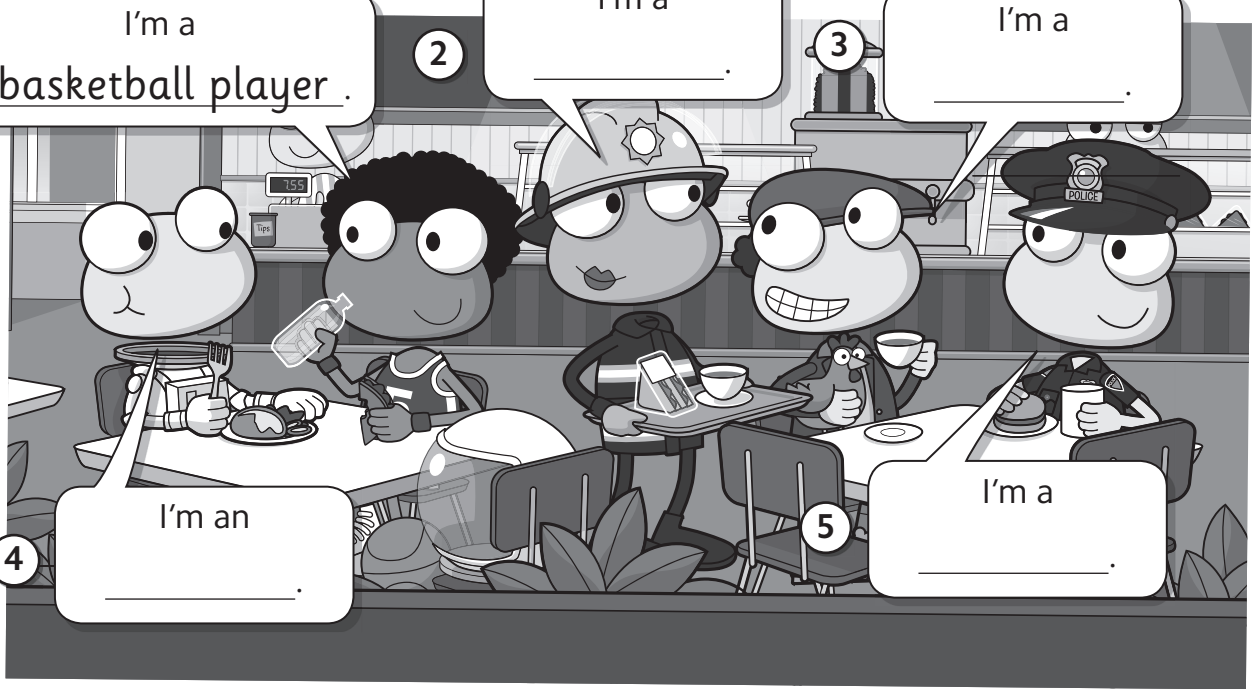

1 I'm a basketball player.







2 I'm a _____.

3 I'm a _____.







4 I'm an _____.

5 I'm a _____.

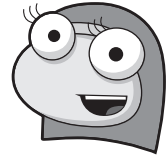
3  Listen and number. Complete the question.

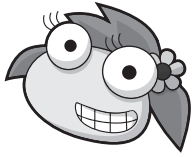
 <input type="checkbox"/>	 <input type="checkbox"/>	 <input type="checkbox"/> 1	<div data-bbox="1197 178 1453 462" style="border: 1px solid black; border-radius: 15px; padding: 10px; display: inline-block;">What _____ _____ want to _____ ?</div>
 <input type="checkbox"/>	 <input type="checkbox"/>	 <input type="checkbox"/>	

4  Look at Activity 3 and write.

1	<u>I want to be a police officer.</u>	
2	<u>_____</u>	
3	<u>_____</u>	
4	<u>_____</u>	
5	<u>_____</u>	
6	<u>_____</u>	
7	<u>_____</u>	

5



Find the jobs and write.



luberid

erathec

toerod

refram

1



She wants to be a doctor.

2



He wants _____.

3



He _____.

4



_____.

6



Find and write the questions. Then listen and write the answers.

1

he want Does to a farmer be

Does he want to be a farmer? No, he doesn't.

2

want be to teacher Does a she

3

a Does want be to he builder

4

doctor she want Does to a be



12



What do you want to be? Write notes.
Then tell your friend.



I want to be...

I like...

I can...

13



Write about what you and your friend want to be.

I want to be _____.

I can _____.

I like _____.

My friend wants to be _____.

He/She _____

_____.

16



Look and write.



1



police officer

2



3



4



5



6



7



8



9

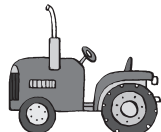

10



17



Listen, read and find the differences. Listen again and write.

I ~~don't~~ like sport. I play basketball on Mondays at 11 o'clock. In the evening I go to the park with my friends. I want to be a film star and I want to be the best! My favourite player is Rajon Rondo. He's so cool! What do you want to do?



1

love

2

3

4

5

I CAN

- I can identify some common jobs.
- I can ask and answer about what people want to be.
- I can understand texts about what others want to be.
- I can write about what I and other children want to be.





6

Rainforest

1  Look and match.

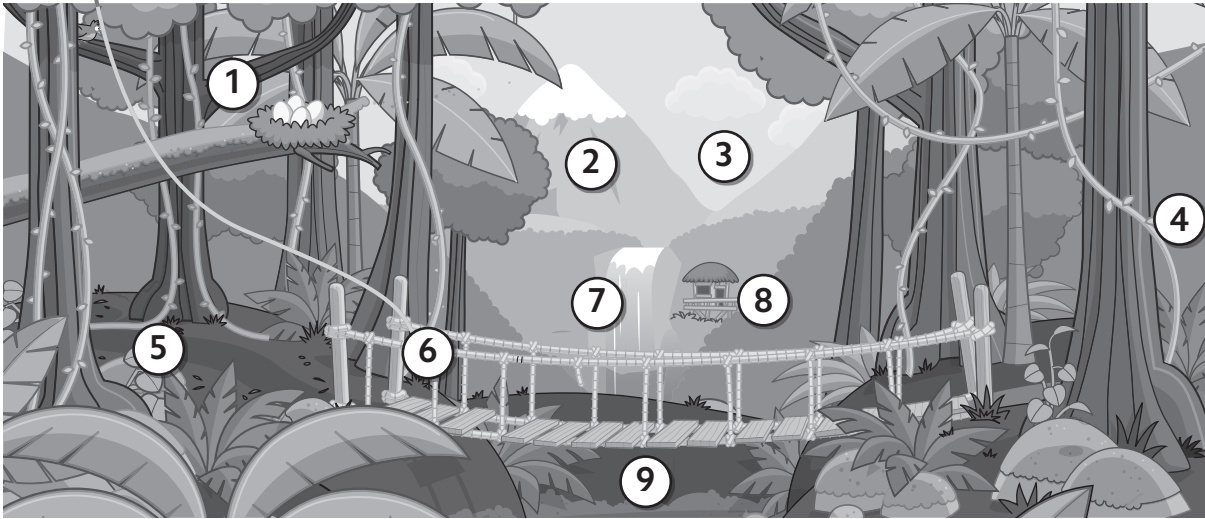
- bridge cave hut mountain nest path river valley waterfall



2  Look, find and write the sentences.

1 swim I river the can in

I can swim in the river.

2 mountain can the climb I

3 the I'm on bridge Look!

4 valley the I can in walk

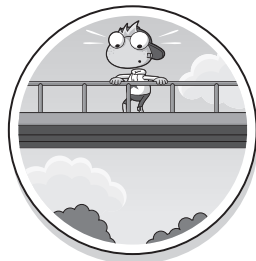

3  Read, look and circle.

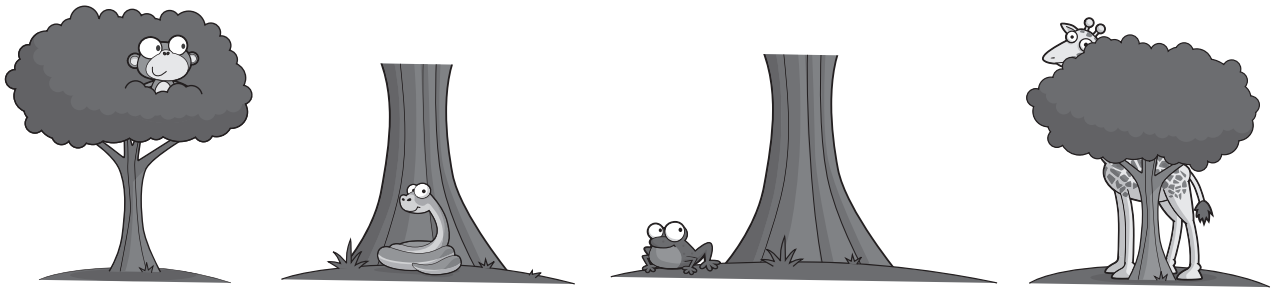

- 1 The monkey is the tree.
- 2 The snake is the tree.
- 3 The frog is the tree.
- 4 The giraffe is the tree.

4  Look and write. Use the words in the box.

behind ~~in front of~~ next to on under

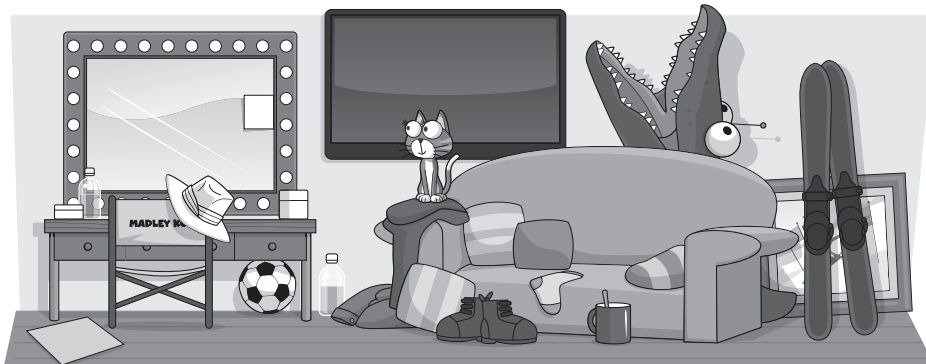

- 1 There's a cat in front of the TV _____.
- 2 There's a football _____.
- 3 There are some skis _____.
- 4 There's a crocodile _____.
- 5 There's a hat _____.

5  Find and write the words.

SONG

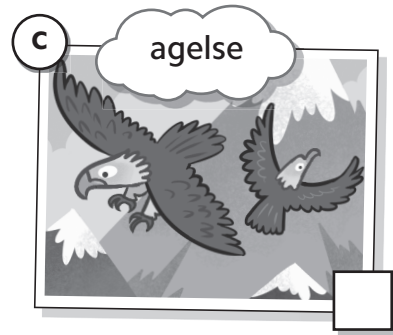
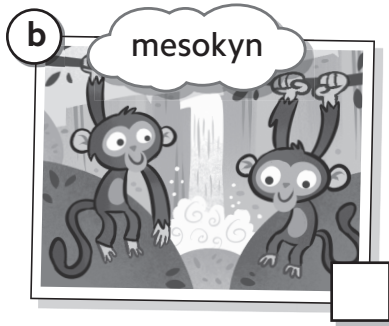
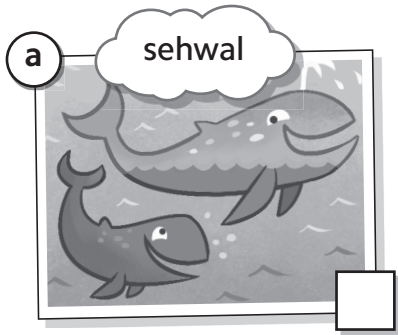

6  Look at Activity 5. Listen and number.

7  Read and complete. Use the words in the box.

arms eyes sharp
strong tails wings

Monkeys live in the rainforest.
They can climb trees. They've got
long ¹ arms and curly
² _____.

Eagles live in the mountains. They can
fly very high. They've got ³ _____
claws and silent ⁴ _____.

Whales live in the sea.
They can swim and they can sing.
They've got ⁵ _____ tails and tiny
⁶ _____.

15



Look, think and write.

WRITING



1 rainforest

Parrots live in the rainforest.

2 long tails

They've got

3 fly

4 fruit and insects

5 pretty

16



Choose a rainforest animal and write about it.
Then tell your friend.

1 _____ live _____.

2 They've got _____.

3 They can _____.

4 They eat _____.

5 They're _____.

19



Find, circle and write ten words from Unit 6.



r	c	o	n	h	c	l	a	w	i
u	a	m	o	u	n	t	a	i	n
w	v	i	x	t	i	w	x	n	b
a	e	l	n	r	v	a	o	g	r
z	n	o	g	f	r	t	i	l	i
r	i	v	e	r	o	e	q	a	g
e	t	y	w	i	f	r	l	t	a
v	a	l	l	e	y	f	e	e	p
m	i	k	s	t	e	a	c	s	u
u	l	r	f	i	m	l	o	m	t

- 1 rainforest 6 c_____
- 2 c_____ 7 t_____
- 3 m_____ 8 h_____
- 4 r_____ 9 w_____
- 5 v_____ 10 w_____

20



Look, find and write.

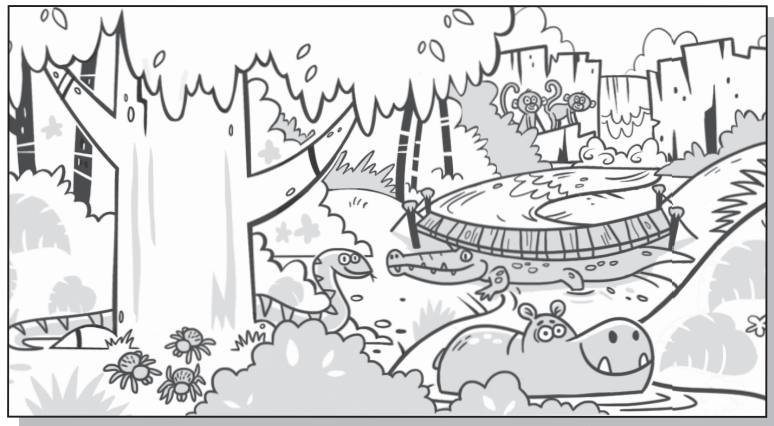

- 1 Where's the crocodile? It's under the bridge.
- 2 Where are the monkeys? They're _____.
- 3 Where's the hippo? It's _____.
- 4 Where are the spiders? _____
- 5 Where's the snake? _____

I CAN

- I can identify some places in the rainforest.
- I can talk about where things are.
- I can understand a text about the rainforest.
- I can write about the environment.



7

Feelings

1  Look and write.
Use the words
in the box.

blushing crying frowning laughing
shaking shouting smiling yawning

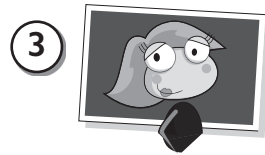
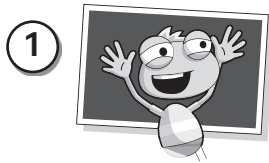

He's laughing. She's _____. She's _____. He's _____.

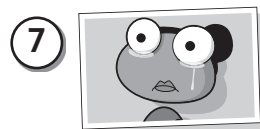

He's _____. He's _____. She's _____. She's _____.

2  Draw the correct faces.

1 The police officer is angry.
She's shouting.



2 The builder is tired.
He's yawning.



3 The film star is sad.
She's crying.



4 The firefighter is happy.
He's smiling.



3



Look and write. Use the words in the box.

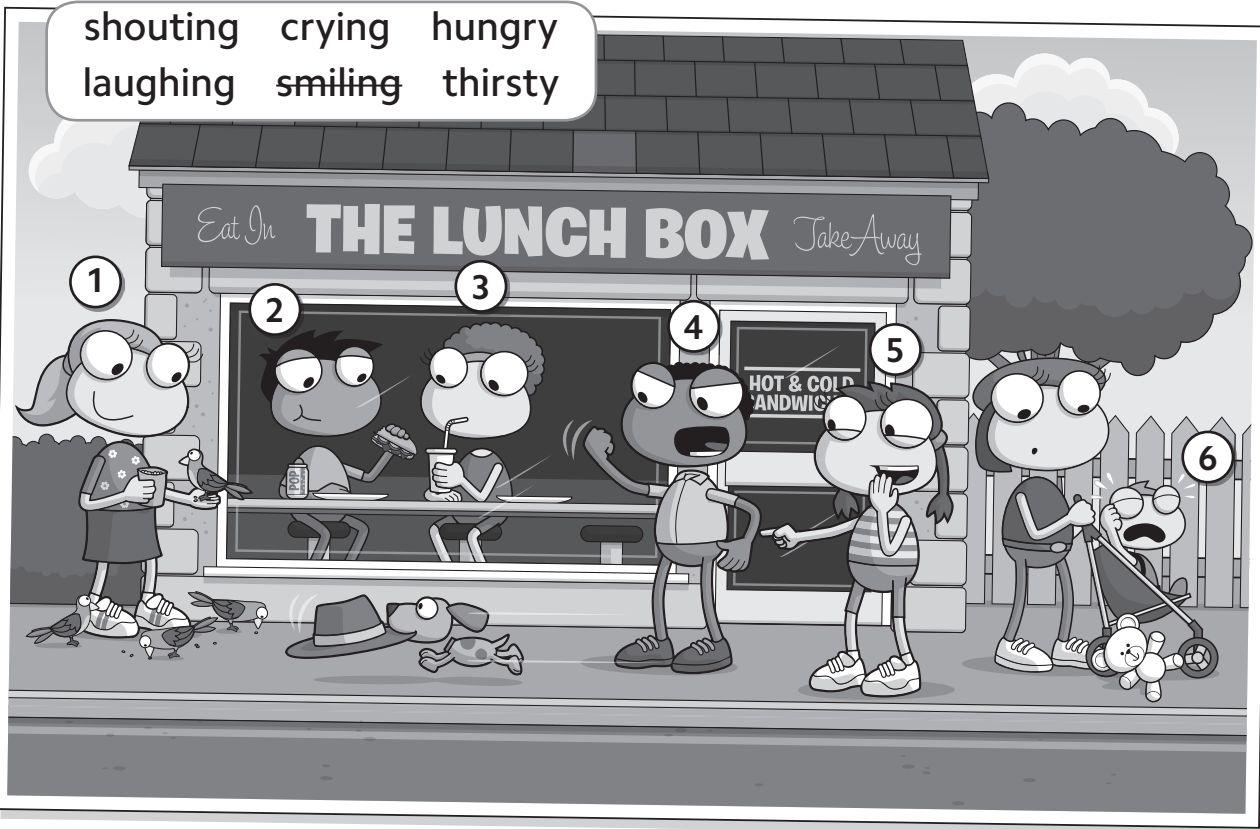

- 1 She's smiling . 2 He's _____ .
 3 She's _____ . 4 He's _____ .
 5 She's _____ . 6 He's _____ .

4



Look at Activity 3. Read and match.

- | | |
|------------------------|--------------------------|
| 1 Why is she smiling? | a Because he's hungry. |
| 2 Why is he eating? | b Because it's funny. |
| 3 Why is she drinking? | c Because she's happy. |
| 4 Why is he shouting? | d Because he's sad. |
| 5 Why is she laughing? | e Because she's thirsty. |
| 6 Why is he crying? | f Because he's angry. |



5 Read the answers and complete the questions. Use the words in the box.

cry happy laugh scared

- 1 What makes you feel scared ? Big storms.
- 2 What makes you feel _____ ? Holidays.
- 3 What makes you _____ ? Naughty monkeys.
- 4 What makes you _____ ? Sad films.

6 Look, think and write.

- 1 They make me feel scared.
- 2 They make me _____.
- 3 They _____.
- 4 They _____.
- 5 They _____.

12



What makes you feel happy and scared? Write notes.

WRITING



13



Write about what makes you feel happy and scared. Then tell your friend.



Birthdays make me feel happy because I like parties.
Crocodiles make me feel scared because they can eat you!

_____ make me feel _____

because _____

16



Look and circle. Draw and write the one that is missing.

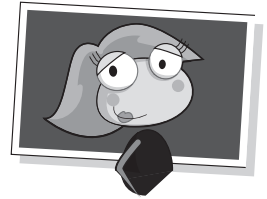
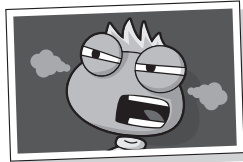
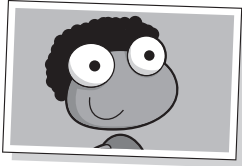

17



Look, think and complete.



Why?
 crying laughing
 shouting smiling

Because
 angry funny
 happy sad



1 Why is she shouting ?
 Because she's angry .

2 Why _____ ?
 Because it's _____ .



3 Why _____ ?
 Because _____ .



4 Why _____ ?
 Because _____ .

I CAN

- I can identify some feelings.
- I can talk about feelings using *Why* and *because*.
- I can recognise how music and films make me feel.
- I can write about how other people feel.



8

By the sea

1  Match.

- fishing
- horse-riding
- kayaking
- sailing
- snorkelling
- surfing

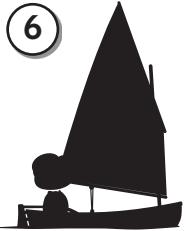
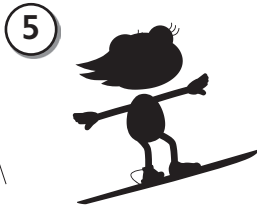
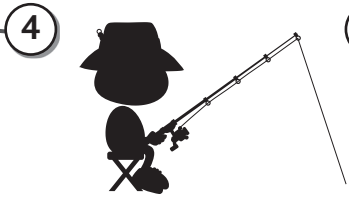
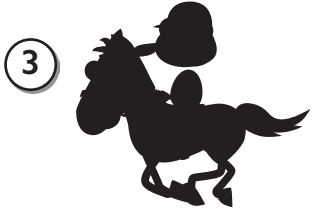

2  Look at Activity 1. Complete the questions and answers.

- 1 What are you going to do ?
I'm going to go kayaking .
- 2 What are you going _____ .
I'm going to go _____ .
- 3 What are you _____ .
I'm going to _____ .
- 4 What are you _____ .
I'm going to _____ .
- 5 What _____ .
I'm _____ .
- 6 _____ .
_____ .

3



Look and answer the questions.

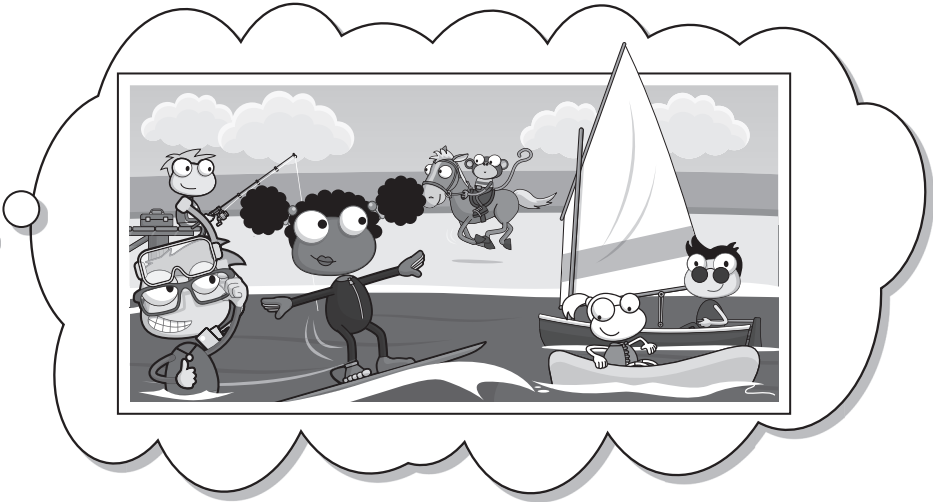

1 What are you going to do tomorrow, Sophie?

I'm going to go surfing .

2 What is Finley Keen going to do?

He's _____ .

3 What is Oliver going to do?

He's _____ .

4 What is Uncle James going to do?

He's _____ .

5 What is Coco going to do?

He's _____ .

4



What are you going to do at the weekend? Write.

Four horizontal lines for writing answers.





Read and complete. Use the words in the boxes. Then listen and check.



bored with

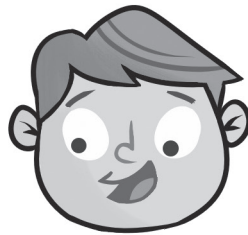

keen on

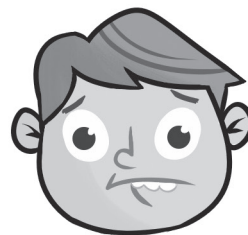



scared of





terrified of

bus drinking plays tennis raining sunny walking watching

Lucy is  ¹ bored with the weather. It's ² raining. She likes ³ _____ weather because she's  ⁴ _____ tennis. She ⁵ _____ on Tuesdays. Today is Tuesday but it's raining.



Lucy is ⁶ _____ to the tennis club. She doesn't go by ⁷ _____ because she's  ⁸ _____ buses. ZAP! A storm! Lucy is  ⁹ _____ storms. Poor Lucy!

Lucy is home again. She's ¹⁰ _____ TV and she's ¹¹ _____ some hot chocolate. She's happy. But there's a spider in the living room. Oh, dear! Lucy is  ¹² _____ spiders. This isn't a very good day!



10





Look, think and complete.

WRITING

Dear Anna,

I'm having a great time here in the  ¹ mountains .

The weather is  ² _____ . I'm really keen on

 ³ _____ . It makes me feel happy. The food is great!

My favourite food is  ⁴ _____ .

How's your holiday?

Lots of love,

Robert

11



Write a postcard about a holiday at the beach.

Dear _____,

I'm having a great time here _____ . The weather is _____ .

_____. It makes me feel happy. The food is great!

How's your holiday?

Lots of _____,



14



Find the odd one out.

- 1 insect cleaning reading skiing
- 2 lion crocodile crying hippo
- 3 Tuesday November Friday Sunday
- 4 scared snowy wet rainy
- 5 astronaut beach basketball player builder
- 6 river waterfall plane rainforest
- 7 horse-riding sailing fishing winter

15



Read and complete. Use the words in the box.

ballet dancer by like morning of
past Saturday skateboarding terrified

Hi, I'm Elizabeth. I ¹ _____ like _____ horse-riding. I'm not scared ² _____
horses but I am ³ _____ of spiders! I love my horse. I like ballet, too.
I want to be a ⁴ _____. I have lessons on Mondays
and Saturdays at school. My lessons start at half
⁵ _____ ⁸ in the ⁶ _____. It's very early!
I go ⁷ _____ bike because it isn't far away.
On ⁸ _____ afternoons I go to the park and
go ⁹ _____ with my friends.



I CAN

- I can identify some outdoor activities.
- I can talk about doing outdoor activities.
- I can understand a text about coral reefs.
- I can write about how other people feel and what they are going to do.

Goodbye

1  Look. Then read and write.

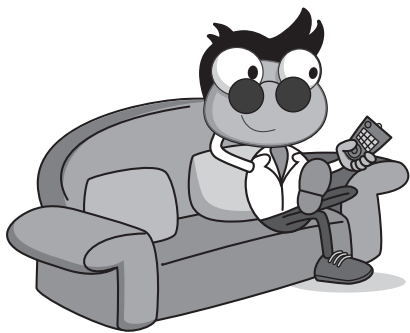

- 1 What's his name? Finley Keen.
- 2 What _____? He likes making films and watching TV.
- 3 Why _____? He's smiling because he's happy.

2  Listen and circle.

1 (a) riding a scooter

(b) skateboarding

(c) skiing

2 (a)



(b)



(c)



3 (a) Coco

(b) Sophie

(c) Oliver

4 (a) English

(b) Maths

(c) Music

5 (a)



(b)



(c)



6 (a) Sophie

(b) Uncle James

(c) Oliver

7 (a) surprised

(b) scared

(c) relaxed

8 (a)



(b)



(c)

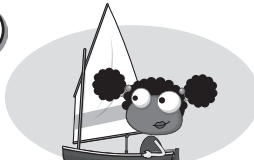

Harvest Festival

1



Read and circle.

1 At Ava's school they celebrate Harvest Festival in **October** **September** .

2 The children take baskets of **fruit and vegetables** **drinks** .

3 At Harvest Festival the children say thank you for their **food** **school** .

4 The children **eat the food** **give the food to people who need it** .

5 Helping people makes Ava feel **happy** **sad** .



2



Read, draw and colour.

Hi! My name is Tom. Today is Harvest Festival at my school. There is a big table in the school hall. In the middle is a big orange pumpkin. There are lots of vegetables. I can see potatoes, carrots, tomatoes and beans. I can see a lot of fruit as well. There are apples, pears and plums. I am next to the table. I've got short brown hair and brown eyes. I'm wearing my school uniform. I'm smiling because Harvest Festival makes me feel happy.

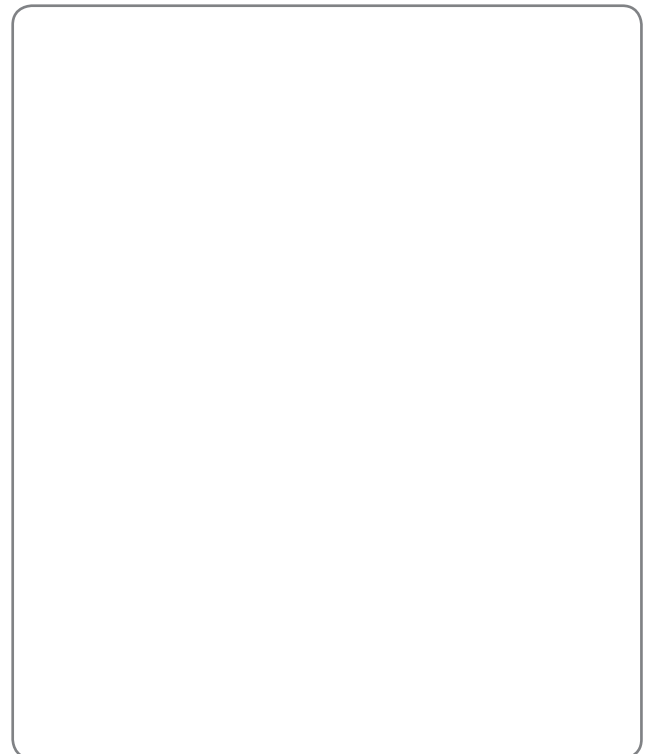

Mother's Day

- 1  Look at the chart and complete the sentences.

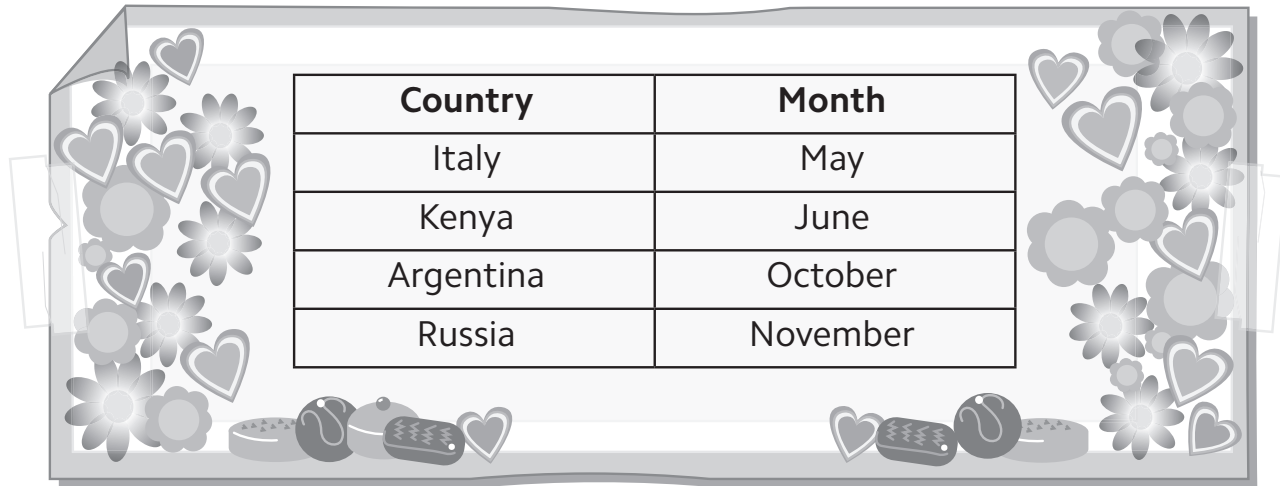

Country	Month
Italy	May
Kenya	June
Argentina	October
Russia	November

- 1 In Italy, Mother's Day is in May.
- 2 In Russia, Mother's Day is in _____.
- 3 In _____, Mother's Day is in June.
- 4 In Argentina, Mother's Day is in _____.
- 5 In my country, Mother's Day is in _____.

- 2  Draw, colour and write a Mother's Day card.

 Have a lovely
Mother's Day!

 Happy
Mother's Day!

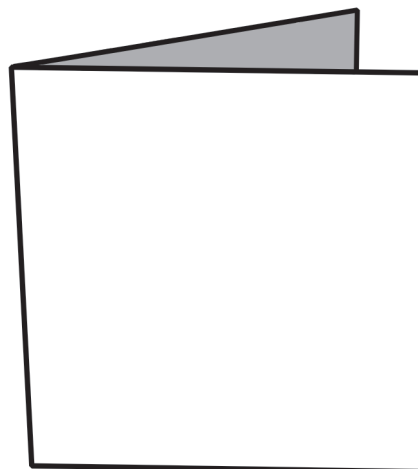

 I love you, Mum!

 Thanks for everything!

 Thank you,
Mum!

May day

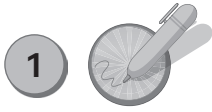

1 Find, circle and write the May Day words.

S	P	H	N	M	Y	T	Y	E	D
U	Y	G	K	A	Q	M	S	P	A
N	R	M	A	Y	P	O	L	E	N
N	D	F	G	Q	T	V	B	N	C
Y	Z	J	O	U	P	I	J	L	I
F	L	O	W	E	R	S	H	J	N
Y	E	K	T	E	M	L	O	L	G
C	R	O	W	N	B	L	K	H	S

- 1 S u _ _ _
- 2 F _ o _ e _ _
- 3 M a _ _ o _ e
- 4 M a _ Q u _ _ n
- 5 C _ o _ _
- 6 D a _ _ i _ _

2 Use the words from Activity 1 and complete.



Hi! My name is Sam. I love May Day. The weather is _____ and there are a lot of _____ in the park. That makes me feel happy. On this day we have a lot of fun. In this photo we are _____ around a _____. I love the colour of all the ribbons. There is a May Queen too. She wears a _____ on her head.

Picture dictionary

Free time



chatting online



riding my scooter



skiing



cooking



watching TV



riding my bike



playing the guitar



skateboarding

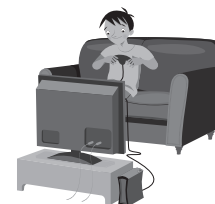

playing computer games

Animals

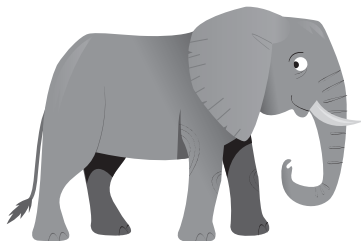

elephant

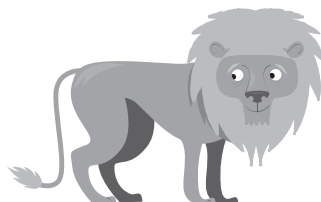

lion



monkey

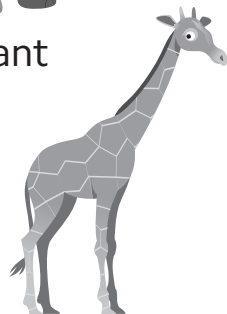

giraffe



crocodile

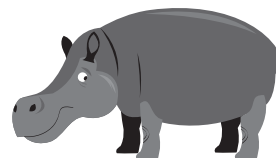

hippo

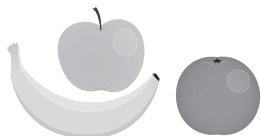

fruit

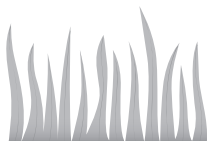

grass



meat



leaves

Seasons



spring



summer



autumn



winter

Weather

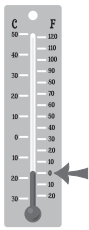

cold

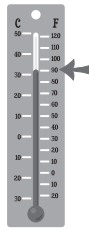

hot



temperature

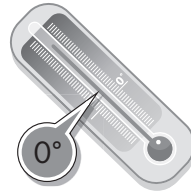

degrees



stormy



thunder



lightning



warm



humid



wet

My week

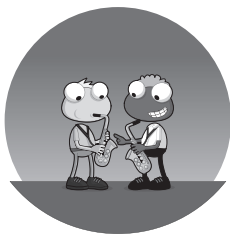

have music lessons

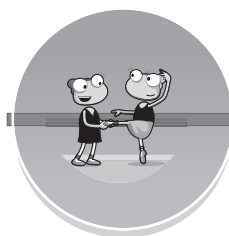

have ballet lessons



do karate

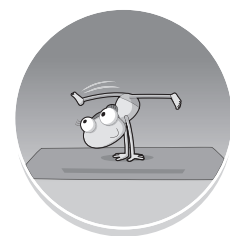

do gymnastics



practise the piano

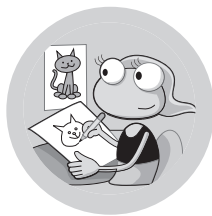

learn to draw



learn to cook

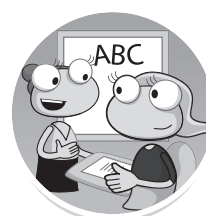

study English

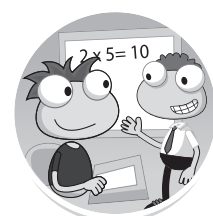

study Maths

Jobs



a firefighter



a police officer



a film star



a farmer



a ballet dancer



a mechanic



a basketball player

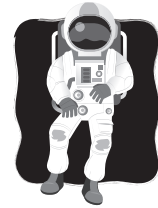

an astronaut

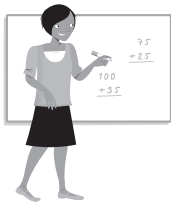

a teacher



a builder



a doctor



a photographer

Rainforest



waterfall

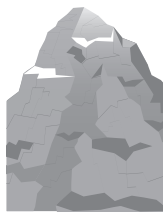

mountain



rainforest



river

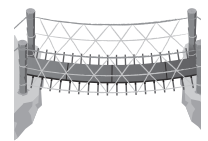

bridge



valley



path



cave



hut

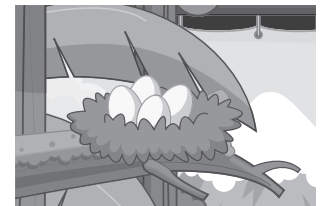

nest

Feelings



yawning

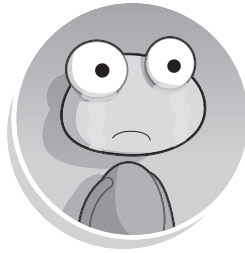

crying



shouting



frowning



laughing



shaking

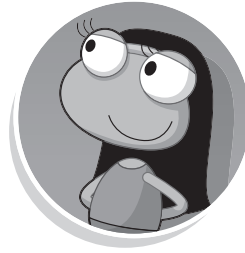

smiling

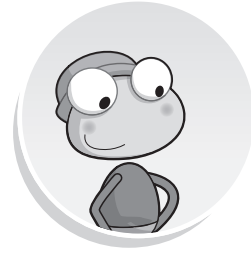

blushing

By the sea



sailing



surfing



snorkelling



horse-riding



fishing



kayaking



beach

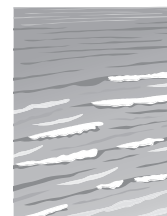

sea

Original edition © Pearson Education Limited 2017

This edition:

Pearson Educación, S.A.

Ribera del Loira 16-18

28042 Madrid

Spain

Poptropica English

© Pearson Educación, S.A. 2019

Published by arrangement with Pearson Education Limited.

The publisher would like to thank Anne Feunteun and Debbie Peters for their contribution.

All rights reserved. Any form of reproduction, distribution, public communication or modification of this work is strictly forbidden without the prior authorisation of the intellectual property copyright holders, unless otherwise stated by Law. The infringement of said copyright may constitute an offence against intellectual property legislation (articles 270 et seq. of the Penal Code). Should you need to photocopy or scan any part of this work, contact CEDRO (Spanish Reproduction Rights Centre. www.conlicencia.com; 91 702 19 70/ 93 272 04 47).

First published 2019

ISBN: 978-84-205-7122-5

Set in Camphor 17/21pt

Illustrators: Humberto Blanco (Sylvie Poggio Artists Agency), Anja Boretzki (Good Illustration), Chan Cho Fai, Lee Cosgrove, Leo Cultura, Marek Jagucki, Jim Peacock (Beehive Illustration), Mark Ruffle (The Organisation), and Yam Wai Lun

Image Credit(s):

Alamy Stock Photo: Kumar Sriskandan, Mark Boulton

Cover Images: *Front:* **Alamy Stock Photo:** Angie Knost, Panther Media GmbH

All other images © Pearson Education

Every effort has been made to trace the copyright holders and we apologize in advance for any unintentional omissions. We would be pleased to insert the appropriate acknowledgement in any subsequent edition of this publication.

Andalusia
edition

Film Studio Island



ISBN 978-84-205-7122-5



9 788420 571225